

HJX29

SPECIFICATIONS

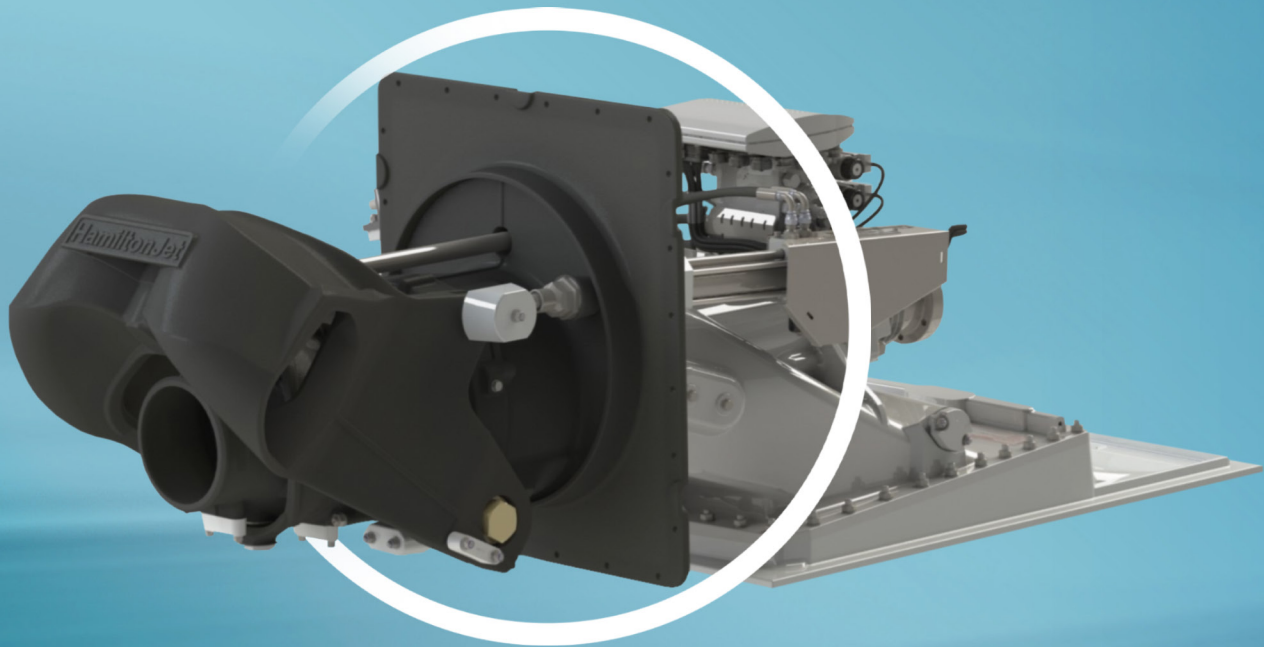

The Ultimate in
Waterjet Sophistication

The HJX29 is our next generation of small waterjets.

The entire series features redefined performance, enhanced durability and easier installation.

HamiltonJet

HJX29

SPECIFICATIONS

HTX29 features:

- Power 440 kW (max)
- RPM 3000 rpm (max)
- Speed 50 Knots
- Jet Weight (At 0°) 200kg (dry)
- Jet Weight (At 5°) 200kg (dry)
- Entrained water 54kg
- Intake block (At 0°) 20.8kg
- Intake block (At 5°) 25.9kg
- LCG (dry fwd of transom) 47mm
- LCG (wet fwd of transom) 177.5mm
- New hydrodynamic & low-loss intake screen design delivers 5% more high speed efficiency than previous model
- 20% increase in peak bollard
- 5 knot better minimum speed
- Available with manual hydraulic & HSRC (bA controls & AVXexpress optional)
- Optimised JT steering system
- Increased impeller rating range for more compatibility with wider range of engines
- Enhanced corrosion protection
- Compact inboard foot print & through transom installation

COMPONENT	MATERIAL	STANDARD
Intake Block	EN AC 44100 Cast Marine Grade Aluminium	BS EN 1706
Intake Material	EN AC 44100 Cast Marine Grade Aluminium	BS EN 1706
Stator Material (without LEI)	EN AC 44100 Cast Marine Grade Aluminium	BS EN 1706
Nozzle Material	EN AC 44100 Cast Marine Grade Aluminium	BS EN 1706
Steering Deflector Material	EN AC 44100 Cast Marine Grade Aluminium	BS EN 1706
Astern Deflector Material	EN AC 44100 Cast Marine Grade Aluminium	BS EN 1706
Mainshaft Material	2205 Duplex Stainless Steel	ASTM 276
Wear Ring Material	2205 Duplex Stainless Steel	ASTM 240
Impeller Material	CF8M Cast Stainless Steel	ASTM A743
Anode Material	High Energy Aluminium (Internal and External)	

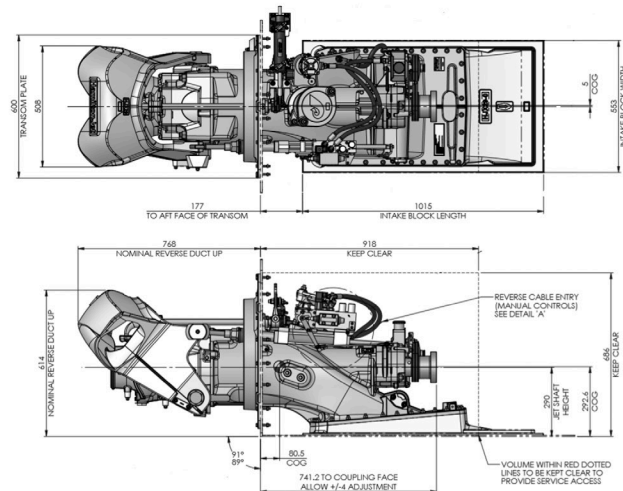

IMPORTANT NOTES: The HJX29 dimensions shown above are *indicative and preliminary dimensions only* for initial design purposes, and subject to change without notice or obligation. Please consult with the factory before using these preliminary dimensions for final installation requirements as these may have changed. Waterjet selection is determined by a range of hull and operational factors, most importantly vessel size and displacement (weight), and not necessarily by matching the above specifications to the desired engine power/RPM curve. In all cases you should consult HamiltonJet for assistance with waterjet selection.

